

NEW Ergonomic Lift Stands

Dual (2x) or Quattro (4x) Synchronized Linear Actuators



Made in USA

Dual Actuator Lift Stand

Specifications: Work space surface can be customized to your customers needs.

(2) FD series actuators – SYNCHRONIZED

(1) HDU-2 Handset 2 button control

(1) Controller CB3T

Lifting capacity: 6000 N (1350 lbs-f)

Power input: 110/230 VAC

Speed: 16 mm/s

Stroke Length Options: 50 mm, 150 mm, 200 mm, 300 mm (customized lengths available)

Preset Limit Switches

Locking wheels

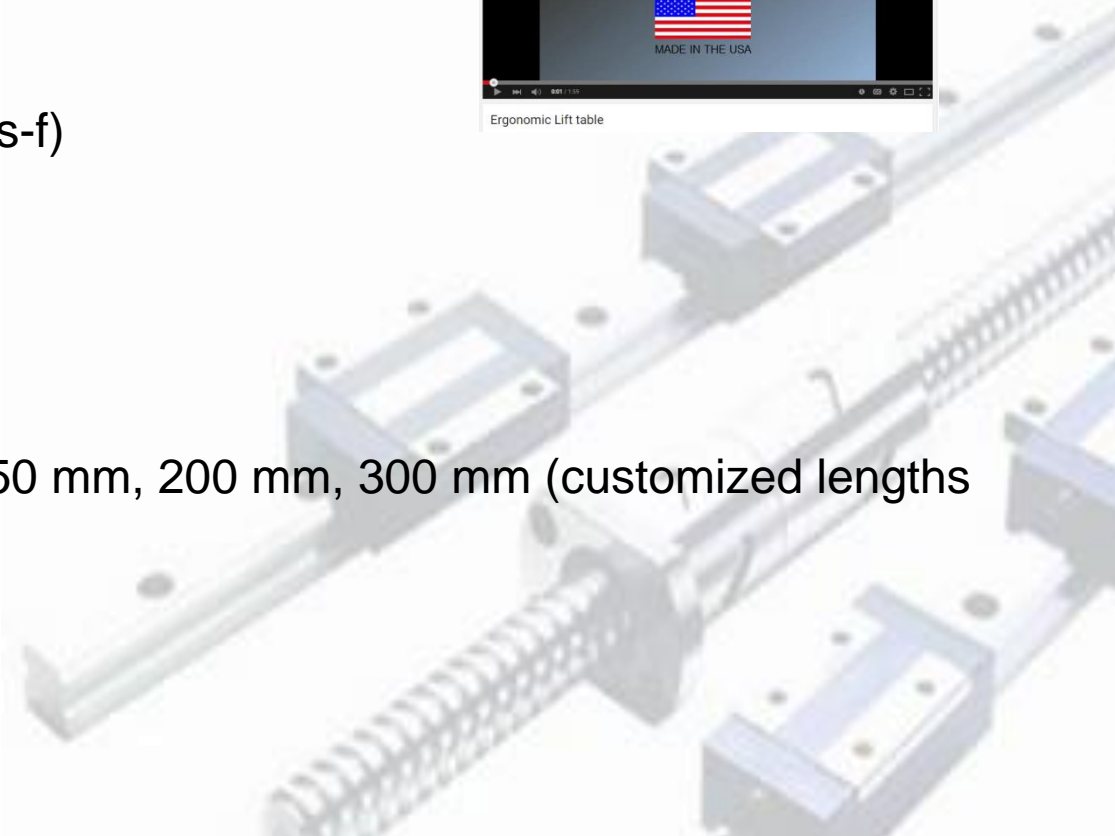

Concept drawing 1st pass

Final Design

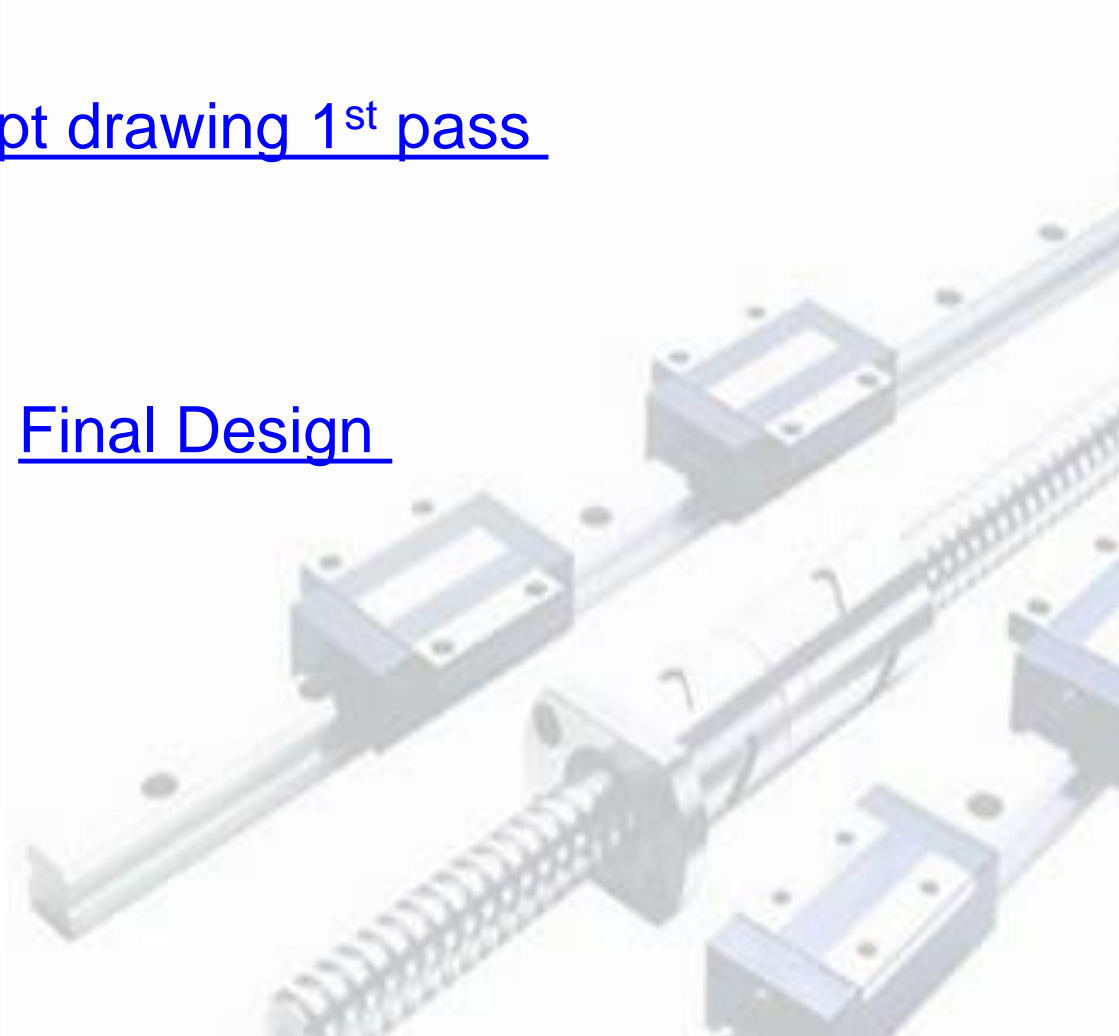

Quattro Actuator Lift Stand

Specifications: Work space surface can be customized for your customers needs.

(4) FD series actuators – SYNCHRONIZED

(1) HDU-2 Handset 2 button control

(1) Controller CB3T

Lifting capacity: 12000 N (2700 lbs.-f)

Power input: 110/230 VAC

Speed: 16 mm/s

Stroke Length Options: 50 mm, 150 mm, 200 mm, 300 mm (customized lengths available)

Preset Limit Switches

Locking wheels

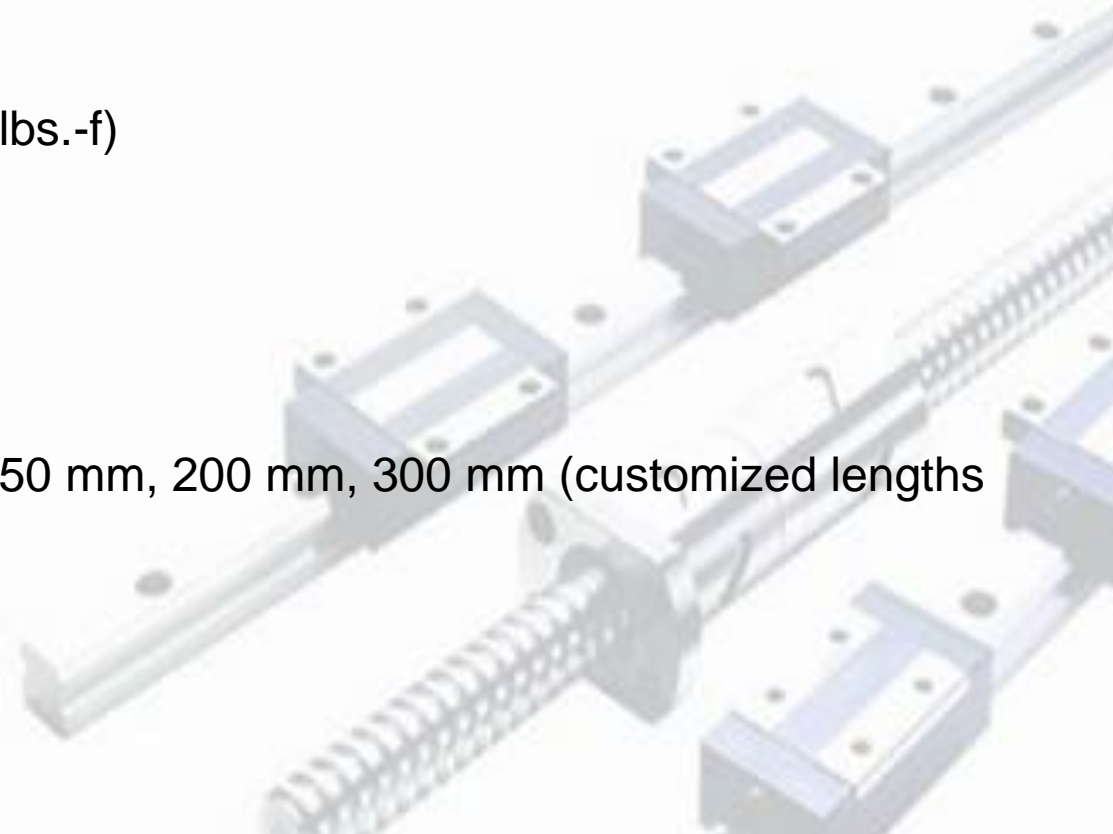

Quattro Actuator Lift Stand



4 Actuator synchronization



Preliminary pricing

Part Number	Quantity	Price	Delivery
DA-EGO-100-XT	1-10	\$1250	4 weeks
DA-EGO-300-XT	1-10	\$1500	4 weeks
QA-EGO-100-XT	1-10	\$1500	4 weeks
QA-EGO-300-XT	1-10	\$1750	4 weeks

